

# Sakura Air Conditioner User-friendly, Earth-friendly

TECHNICAL MANUAL

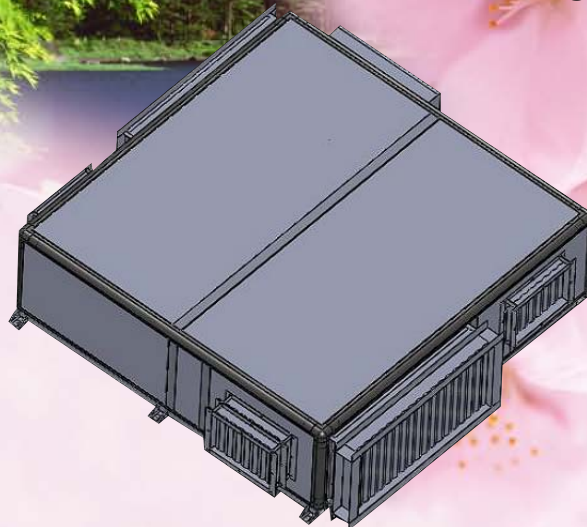

Packaged "Room Top" Air conditioner  
HPACK-RH Series

## ● FEATURES AND BENEFITS

Efficient cooling, easy installation and time-saving maintenance are all attainable by one single unit..

- By hi-COP Scroll Compressor being equipped, the unit is highly efficient and most welcomed by commercial building owners.
  - This unit is designed especially for commercial use for its extra low noise by heavy insulation and special vibration-resistant construction being installed within a limited space at room top. The compact, space-saving, unit fit easily and securely to an available position at a ceiling in a minimal time and cost of installation.
  - If required, the unit can also be used as a Split System to mount the condenser section horizontally. Centrifugal fans also allow ducting both as Air Evaporator and Condenser.
  - With easily removed five access panels, quick and convenient reach to all components when needed to extend maintenance. Additionally, all required service/maintenance to the unit can be extended from one side, allowing the unit can be installed against a wall or ceiling, obviously a space-saving.
  - Specially designed Scroll compressor for high efficiency is mounted internally by spring to minimize vibration noise and is hermetically sealed against contamination to assure longer life and dependable operation.
-

● **UNIT FEATURES**

The HPAK-ROOM (H) series Stand-Alone air conditioner is available in six (6) different sizes with a complete series of accessories. They are designed for the air-conditioning of medium spaces. The unit fulfills all possible needs by different installation solutions with following versions:

- A) Ducted intake directly from the environment
- B) Intake with mixing chamber

Prior to shipment, all the units are severely tested to be delivered with oil and refrigerant charged. They may also be delivered by different type of free-cooling control fitted.

**Partial load operation**

Each model number stands for maximum possible load while they usually have a room as the unit is operated usually with its partial load. HPAK-ROOM(H) feature particularly high efficiency with partial loads. Using this type of product in all installations where loads vary results in significant energy savings.

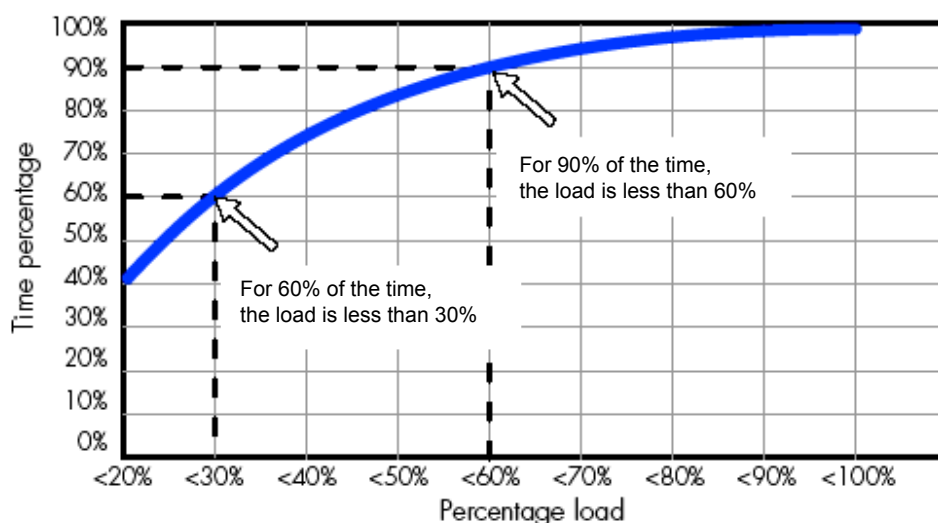

**Condensate Fan speed control**

By adding Condensate Fan Speed Control device, the unit considerably reduces the energy consumed for condensation. This device makes use of electronically controlled, high efficiency fans with sophisticated speed adjustment whereby consumption is greatly reduced and noise is extremely limited.

**SPECIFICATIONS OF STANDARD UNIT**

**COMPRESSOR**

Hermetic orbiting scroll compressor complete with motor over-temperature and over-current devices and protection against excessive gas discharge temperature. Fitted on rubber anti-vibration mounts and complete with oil charge.

**STRUCTURE**

Structure made from "aluzink" plate, providing excellent mechanical characteristics and extensive corrosion strength.

**PANELLING**

Pre-painted steel-plate external paneling, easily removed for trouble-free access to internal components. The air handling section is completely lined with Class 1 fire resistant material providing optimum heat insulation and acoustic isolation.

**ROOM-TOP AIR-CONDITIONER 90-200 .....3**

---

**INTERNAL EXCHANGER**

Direct expansion finned exchanger, made from copper pipes in staggered rows and mechanically expanded to the fin collars. The fins are made from aluminium with a corrugated surface and adequately distanced to ensure the maximum heat exchange efficiency.

**EXTERNAL EXCHANGER**

Direct expansion finned exchanger, made from copper pipes in staggered rows and mechanically expanded to the fin collars. The fins are made from aluminium with a corrugated surface and adequately distanced to ensure the maximum heat exchange efficiency.

**FAN**

- Dual intake centrifugal fan with forward blades for maximum efficiency and low noise. Statically and dynamically balanced according to the ISO 1940 standards, section 6.3. Fitted on rubber antivibration mounts. The scroll, the rotor and the frame are made from galvanized steel plate (dip-zinc coated).

**REFRIGERANT CIRCUIT**

each circuit includes:

- refrigerant charge
- high pressure switch
- low pressure switch
- thermostatic expansion valve
- dehydrator filter

**FILTRATION**

Flat filter, made up of a galvanized plate frame with galvanized and electricwelded protective mesh and 100% regenerable polyester filtering media with PVC resin. G2 efficiency according to CEN -EN 779 standard (Eurovent class EU4/5 - average efficiency 79% ASHRAE 52-76 Atm). Self-extinguishing (resistance to fire class 1 - DIN 53438).

**ELECTRICAL PANEL**

the Power Section includes:

- main door lock isolator switch
- compressor control contactor
- fan control contactors

the control section includes:

- microprocessor control
- compressor overload protector and timer
- centralized alarms with remote signalling
- phase monitor
- remote ON/OFF control
- electronic thermostat for air temperature control

**ACCESSORIES**

- hot water heating coil (2R)
  - Electric heating coil
  - F5 high efficiency air filters in lieu of standard ones
  - Free-cooling with only the temperature comparison
  - CO2 detection to keep the density flat
  - Local control portable keypad for unit control and configuration
  - rubber antivibration mounts
-

**CONFIGURATION**

DIRECT DUCT INTAKE (A)

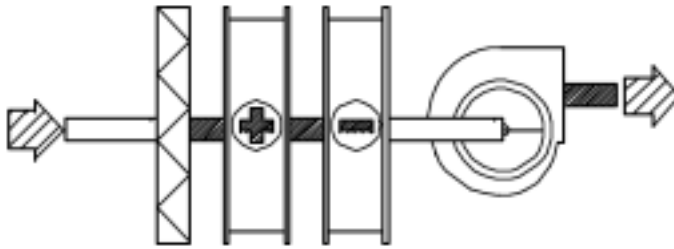

Configuration A is a basic unit and B and C are further developed, as described below. The air-conditioner is fitted for ducted intake directly from the room.

RECIRCULATED/OUTSIDE AIR MIXING BOX(B)

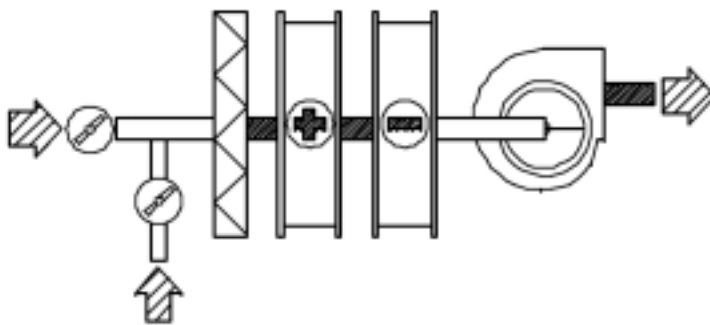

The B configuration allows a diversified air return according to the different needs of the installation. The unit is equipped with a damper on the fresh air intake for a partial air renewal or for Free-cooling function. The damper can be adjusted to obtain a correct air mixing and can be controlled by a servo-motor. A rain hood with mesh pre-filter is included in the standard scope of supply. It is available, as an accessory, a damper on the return air intake to adjust properly air renewal higher than 40%.

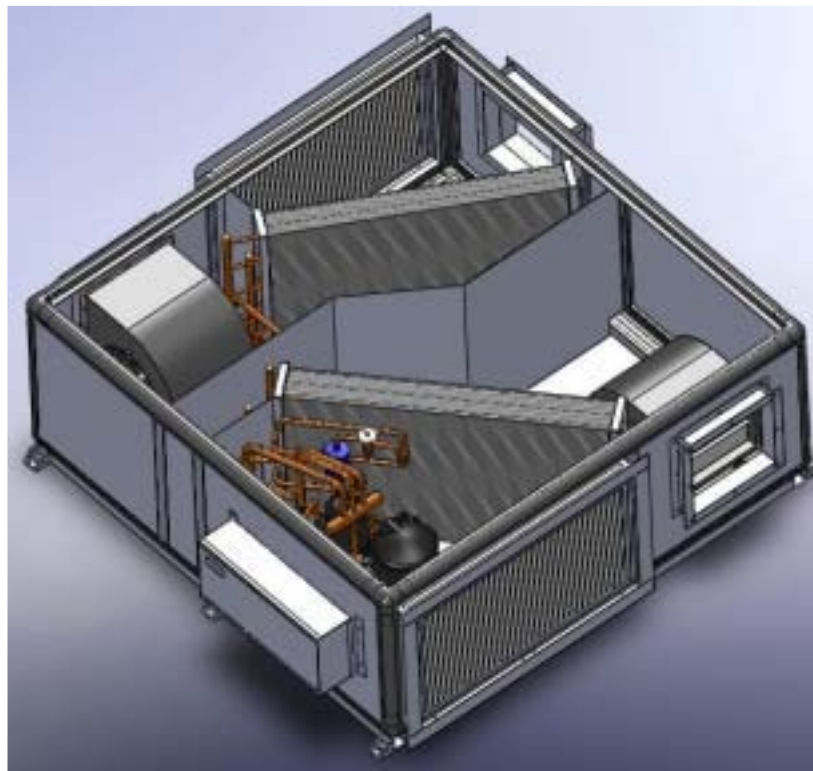

## CONFIGURATION CODE

	(1)	(2)	(3)	(4)	(5)	(6)	(7)
HPACK-ROOM	90	A	150	120	SM	SR	

(1). HPACK-ROOM COOLING ONLY; HPACK-ROOM-H HEAT PUMP

(2). COOLING CAPACITY (9KW)

(3). CONSTRUCTIONAL CONFIGURATION

Direct ductable intake (A)

Recirculated /outside air mixing box(B)

(4) OUTLET STATIC PRESSURE VALUE (Pa)

(5) INTAKE STATIC PRESSURE VALUE

(6) AIR FLOW

Standard air flow (SM)

Reduced air flow (RM)

Air flow high (HM)

(7) INTAKE AIR FLOW

Standard air flow (SR)

Reduced air flow (RR)

Air flow high (HR)

## SOUND LEVELS

Air flow: Standard air flow

MODEL	Sound Power Level (dB)								Sound pressure level dB(A)	Sound power level dB(A)
	Octave band (Hz)									
	63	125	250	500	1000	2000	4000	8000		
90	76	89	71	69	70	68	67	54	62	77
100	43	64	87	69	67	63	61	66	59	74
130	73	87	75	75	73	69	69	53	63	78
150	73	84	77	77	75	69	68	53	64	79
180	83	89	83	81	80	75	72	63	69	85
200	83	86	83	81	81	76	73	70	69	85

The sound levels refer to the unit at full load, in the rated test conditions.

The sound pressure level refers to a distance of 1m from the external surface of the units operating in an open field.

## Electrical heater (optional)

Electrical heater	90	100	130	150	180	200
4.5 kW	X	X	X	X	X	X
6 kW			X	X	X	X
9 kW				X	X	X

The heating elements require a 400/3/50. The frame is in galvanized steel. The section is complete with circuit breaker, safety thermostat and PCB for connection to our electronic control.

**HOT WATER COIL (optional)**

Size	90		100		130		150		180		200	
Ta (°C)	Ti/To											
	80/70	80/60	80/70	80/60	80/70	80/60	80/70	80/60	80/70	80/60	80/70	80/60
10	18.1	15.8	25.2	22.3	28.7	25.4	37.9	33.6	42.2	37.6	47	41.8
15	16.8	14.4	23.3	20.3	26.7	23.1	34.8	30.5	38.5	34	42.9	37.8
20	15.3	13	21.4	18.4	24.4	20.8	31.7	27.3	34	30.5	39	33.8
25	13.8	11.8	19.3	16.3	22	18.4	28.5	24.2	31.4	27	35	29.9

Ta = AIR INLET TEMPERATURE OF HOT WATER COIL (°C)

Ti/To = WATER TEMPERATURE INLET/OUTLET (°C)

**HOT WATER COIL PRESSURE DROP - WATER SIDE**

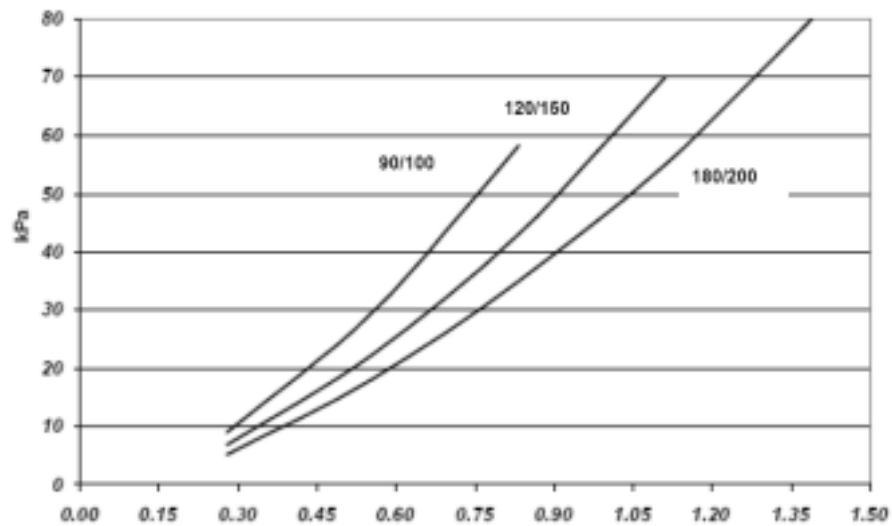

WATER PRESSURE DROP IS CALCULATED CONSIDERING A MEDIUM WATER TEMPERATURE OF 72°C

**HOT WATER COIL PRESSURE DROP - AIR SIDE**

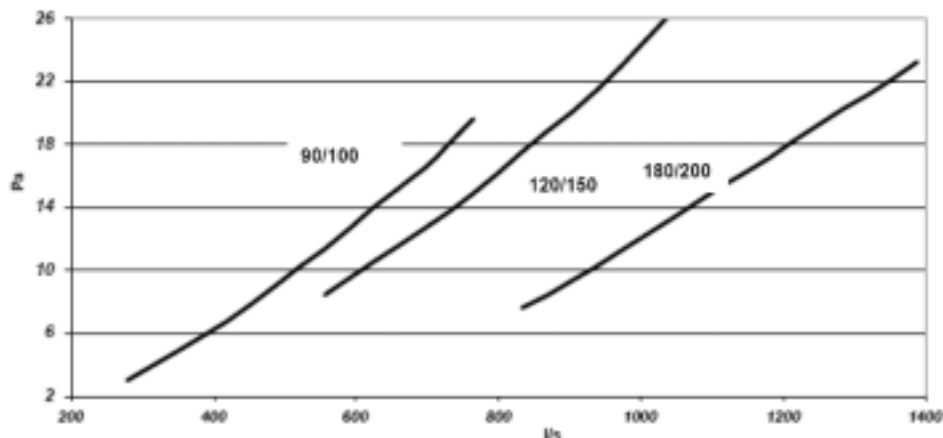

AIR PRESSURE DROP IS CALCULATED AT STANDARD AIR TEMPERATURE. THE PRESSURE DROP HAS TO BE ADDED TO PRESSURE DROPS DUE TO AIR DUCTS, AIR SUPPLY GRILLE AND OTHER ITEM MAY CREATE A LOSS OF STATIC PRESSURE.

## SPECIFICATIONS

### HPACK-ROOM

#### SPECIFICATIONS -----INDOOR INSTALLATION

Size		90	100	130	150	180	200	250	300
------	--	----	-----	-----	-----	-----	-----	-----	-----

#### COOLING

Cooling capacity	1	kW	8.7	10.5	12.9	15.3	18.7	20.7	26	30.0
Sensible capacity	1	kW	6.4	8.2	9.8	11.3	14.3	16.2	18.5	20.8
Compressor power input	1	kW	2.29	2.76	3.39	4.03	4.92	5.45	6.84	7.89
EER			2.86	2.75	2.84	2.77	2.72	2.80	2.86	2.91

#### COMPRESSOR

Type of compressors	2		Scroll	Scroll	Scroll	Scroll	Scroll	Scroll	Scroll	Scroll
No. of Compressors		Nr	1	1	1	1	1	1	1	1
Std Capacity control steps		Nr	1	1	1	1	1	1	1	1
Oil charge (C1)		l	1.1	1.1	1.36	1.65	1.65	1.65	4	4
Refrigerant charge (C1)		kg	3.3	3.3	3.6	3.7	4.9	5.2	7	8.5
Refrigerant circuits		Nr	1	1	1	1	1	1	1	1

#### AIR HANDLING SECTION FANS (OUTLET)

Type of fans	3		CFG	CFG	CFG	CFG	CFG	CFG	CFG	CFG
Number of fans		Nr	1	1	1	1	1	1	1	1
Standard air flow		l/s	417	598	722	837	1030	1222	1280	1500
Nominal static pressure		Pa	90	80	115	90	160	120	170	170

#### EXTERNAL SECTION FANS

Type of fans	3		CFG	CFG	CFG	CFG	CFG	CFG	CFG	CFG
Number of fans		Nr	1	1	1	1	1	1	1	1
Standard air flow		l/s	800	870	1080	1250	1350	1650	1800	2200
Nominal static pressure		Pa	50	50	50	50	50	50	50	50

#### STANDARD UNIT WEIGHTS

Shipping weight		kg	160	170	200	203	270	270	400	400
-----------------	--	----	-----	-----	-----	-----	-----	-----	-----	-----

#### DIMENSIONS

Length		mm	1200	1200	1480	1480	1680	1680	2080	2080
Depth		mm	1200	1200	1480	1480	1680	1680	2080	2080
Height		mm	600	600	600	600	700	700	700	700

(1) Ambient temperature 27°C/19.5 WB outside temperature 35°C

(2) SCROLL = scroll compressor

(3) CFG = centrifugal fan

**HPACK-ROOM-H  
SPECIFICATIONS**

Size	90	100	130	150	180	200	250	300
------	----	-----	-----	-----	-----	-----	-----	-----

**COOLING**

Cooling capacity	1	kW	8.7	10.5	12.9	15.3	18.7	20.7	26	30.0
Sensible capacity	1	kW	6.4	8.2	9.8	11.3	14.3	16.2	18.5	20.8

**HEATING**

Heating capacity	4	KW	9.0	11	13.2	16	19.2	21.5	27.1	31
Compressor power input	1	kW	2.29	2.76	3.39	4.03	4.92	5.45	6.84	7.89
EER unit			2.86	2.75	2.84	2.77	2.72	2.80	2.86	2.91
C.O.P			2.96	2.88	2.90	2.90	2.79	2.91	2.98	3.01

**COMPRESSOR**

Type of compressors	2		Scroll	Scroll	Scroll	Scroll	Scroll	Scroll	Scroll	Scroll
No. of Compressors		Nr	1	1	1	1	1	1	1	1
Std Capacity control steps		Nr	1	1	1	1	1	1	1	1
Oil charge (C1)		l	1.1	1.1	1.36	1.65	1.65	1.65	4	4
Refrigerant charge (C1)		kg	3.3	3.3	3.6	3.7	4.9	5.2	7	8.5
Refrigerant circuits		Nr	1	1	1	1	1	1	1	1

**AIR HANDLING SECTION FANS (OUTLET)**

Type of fans	3		CFG	CFG	CFG	CFG	CFG	CFG	CFG	CFG
Number of fans		Nr	1	1	1	1	1	1	1	1
Standard air flow		l/s	417	598	722	837	1030	1222	1280	1500
Nominal static pressure		Pa	90	80	115	90	160	120	170	170

**EXTERNAL SECTION FANS**

Type of fans	3		CFG	CFG	CFG	CFG	CFG	CFG	CFG	CFG
Number of fans		Nr	1	1	1	1	1	1	1	1
Standard air flow		l/s	800	870	1080	1250	1350	1650	1800	2200
Nominal static pressure		Pa	50	50	50	50	50	50	50	50

**STANDARD UNIT WEIGHTS**

Shipping weight		kg	160	170	200	203	270	270	370	370
-----------------	--	----	-----	-----	-----	-----	-----	-----	-----	-----

**DIMENSIONS**

Length		mm	1200	1200	1480	1480	1680	1680	2080	2080
Depth		mm	1200	1200	1480	1480	1680	1680	2080	2080
Height		mm	560	560	600	600	700	700	700	700

(1) Ambient temperature 27°C/19.5 WB outside temperature 35°C

(2) SCROLL = scroll compressor

(3) CFG = centrifugal fan

• 6• Ambient temperature 20°C, outside temperature 7°C DB/ 6°C WB.

**CONFIGURATION: Return air inlet (A) and mixing box for recycle/fresh air (B)**

**ELECTRICAL DATA**

<b>Model HPACK-ROOM</b>		<b>90</b>	<b>100</b>	<b>130</b>	<b>150</b>	<b>180</b>	<b>200</b>	<b>250</b>	<b>300</b>
-------------------------	--	-----------	------------	------------	------------	------------	------------	------------	------------

**F.L.A. - FULL LOAD CURRENT AT MAX ADMISSIBLE CONDITIONS**

<b>F.L.A. - Compressor 1</b>	<b>A</b>	4.92	5.3	7.0	7.18	8.48	11.06	13.03	15
<b>F.L.A. - Single External Fan</b>	<b>A</b>	0.68	0.91	1.06	1.36	1.67	1.67	1.97	1.97
<b>F.L.A. - Single Outlet fan</b>	<b>A</b>	0.45	0.68	0.68	0.91	1.28	1.28	1.44	1.67
<b>F.L.A. - Total</b>	<b>A</b>	6.05	6.89	8.97	9.45	11.4	14.01	16.44	18.64

**L.R.A. LOCKED ROTOR AMPERES**

<b>L.R.A. - Compressor 1</b>	<b>A</b>	40	46	50	66	74	101	123	127
------------------------------	----------	----	----	----	----	----	-----	-----	-----

**F.L.I. FULL LOAD POWER INPUT AT MAX ADMISSIBLE CONDITION**

<b>F.L.I. - Compressor 1</b>	<b>kW</b>	3.25	3.5	4.6	4.74	5.6	7.3	8.6	9.9
<b>F.L.I. - Single External Fan</b>	<b>kW</b>	0.45	0.6	0.7	0.9	1.1	1.1	1.3	1.3
<b>F.L.I. - Single Outlet fan</b>	<b>kW</b>	0.3	0.45	0.45	0.6	0.85	0.85	0.95	1.1
<b>F.L.I. - Total</b>	<b>kW</b>	4.0	4.55	5.75	6.24	7.55	9.25	10.85	12.3

**M.I.C. MAXIMUM INRUSH CURRENT**

<b>M.I.C. - Value</b>	<b>A</b>	44.3	50.7	55.3	73.2	82.4	109.4	129.4	135.9
-----------------------	----------	------	------	------	------	------	-------	-------	-------

Power supply: 400/3/50 Hz +/-6%

Voltage unbalance: max 2 %

Values not including accessories



**COOLING PERFORMANCE**

AIR FLOW: STANDARD

Size	Ta (°C) DB/WB	EXTERNAL EXCHANGER AIR INTAKE TEMPERATURE (°C)																	
		25			30			32			35			40			43		
		kWf	kWe	kWs	kWf	kWe	kWs	kWf	kWe	kWs	kWf	kWe	kWs	kWf	kWe	kWs	kWf	kWe	kWs
90	22 / 16	8.45	1.87	6.09	8.16	2.11	5.94	8.04	2.20	5.88	7.85	2.35	5.79	7.52	2.61	5.64	7.30	2.77	5.55
	24 / 17	8.70	1.89	6.53	8.41	2.13	6.39	8.28	2.22	6.33	8.09	2.38	6.25	7.76	2.65	6.10	7.55	2.77	5.55
	26 / 19	9.24	1.92	6.50	8.91	2.17	6.36	8.78	2.27	6.30	8.57	2.44	6.21	8.22	2.72	6.07	8.01	2.91	5.98
	27 / 19.5	9.38	1.94	6.71	9.04	2.18	6.56	8.90	2.29	6.50	8.69	2.45	6.42	8.34	2.74	6.27	8.12	2.93	6.18
	28 / 21	9.81	1.97	6.41	9.44	2.22	6.26	9.29	2.33	6.20	9.06	2.50	6.10	8.67	2.81	5.95	8.44	3.01	5.86
	30 / 22	10.1	2.00	6.74	9.71	2.25	6.58	9.55	2.36	6.52	9.30	2.54	6.42	8.89	2.86	6.27	8.64	3.07	6.17
100	22 / 16	10.2	2.11	7.67	9.85	2.37	7.50	9.71	2.48	7.44	9.49	2.65	7.34	9.12	2.94	7.17	8.90	3.13	7.07
	24 / 17	10.5	2.12	8.26	10.1	2.38	8.10	9.99	2.49	8.04	9.78	2.66	7.94	9.43	2.95	7.78	9.22	3.13	7.68
	26 / 19	11.2	2.14	8.23	10.8	2.40	8.07	10.6	2.51	8.01	10.4	2.67	7.92	10.0	2.96	7.76	9.80	3.14	7.67
	27 / 19.5	11.3	2.14	8.51	10.9	2.40	8.35	10.8	2.51	8.29	10.5	2.68	8.20	10.2	2.96	8.04	9.92	3.15	7.95
	28 / 21	11.8	2.15	8.13	11.5	2.40	7.97	11.3	2.51	7.91	11.0	2.68	7.81	10.6	2.98	7.65	10.3	3.17	7.56
	30 / 22	12.2	2.16	8.62	11.9	2.40	8.46	11.7	2.51	8.39	11.4	2.68	8.29	10.8	2.99	8.13	10.5	3.20	8.03
130	22 / 16	12.4	2.64	9.29	12.0	2.94	9.09	11.8	3.07	9.02	11.5	3.27	8.90	11.0	3.61	8.70	10.7	3.82	8.58
	24 / 17	12.8	2.64	9.94	12.4	2.95	9.75	12.2	3.08	9.67	11.9	3.28	9.56	11.4	3.63	9.37	11.0	3.85	9.25
	26 / 19	13.6	2.66	9.84	13.2	2.98	9.65	13.0	3.11	9.58	12.7	3.32	9.47	12.1	3.68	9.28	11.7	3.91	9.16
	27 / 19.5	13.8	2.67	10.2	13.4	2.99	9.98	13.2	3.12	9.91	12.9	3.33	9.79	12.3	3.70	9.60	11.9	3.93	9.49
	28 / 21	14.5	2.69	9.83	14.0	3.02	9.64	13.8	3.16	9.56	13.5	3.37	9.44	12.9	3.75	9.25	12.5	3.98	9.73
	30 / 22	14.9	2.71	10.6	14.4	3.05	10.4	14.2	3.19	10.3	13.8	3.41	10.2	13.2	3.79	10.0	12.8	4.02	9.90
150	22 / 16	14.8	3.23	10.9	14.2	3.59	10.6	14.0	3.73	10.5	13.6	3.96	10.4	13.1	4.34	10.1	12.7	4.58	9.95
	24 / 17	15.2	3.27	11.6	14.7	3.62	11.3	14.5	3.77	11.2	14.1	4.00	11.1	13.4	4.39	10.8	13.0	4.64	10.6
	26 / 19	16.2	3.36	11.5	15.7	3.71	11.2	15.5	3.86	11.1	15.1	4.09	10.9	14.2	4.50	10.7	13.7	4.76	10.5
	27 / 19.5	16.5	3.38	11.8	16.0	3.73	11.5	15.7	3.88	11.4	15.3	4.11	11.3	14.5	4.53	11.0	13.9	4.79	10.8
	28 / 21	17.2	3.46	11.5	16.7	3.81	11.2	16.4	3.96	11.1	16.0	4.20	10.9	15.2	4.61	10.6	14.7	4.87	10.5
	30 / 22	17.7	3.52	12.3	17.1	3.87	12.1	16.9	4.02	11.9	16.5	4.26	11.8	15.8	4.67	11.5	15.3	4.93	11.4
180	22 / 16	18.2	3.79	13.5	17.6	4.19	13.2	17.3	4.36	13.0	16.9	4.63	12.8	16.1	5.13	12.5	15.6	5.45	12.4
	24 / 17	18.7	3.82	14.5	18.0	4.22	14.2	17.8	4.39	14.1	17.4	4.66	13.9	16.7	5.13	13.6	16.3	5.44	13.4
	26 / 19	19.8	3.87	14.4	19.1	4.27	14.1	18.8	4.43	14.0	18.4	4.69	13.9	17.7	5.16	13.6	17.3	5.45	13.4
	27 / 19.5	20.1	3.88	14.9	19.4	4.27	14.6	19.1	4.44	14.5	18.7	4.70	14.3	18.0	5.17	14.1	17.5	5.46	13.9
	28 / 21	21.0	3.91	14.2	20.3	4.28	13.9	20.0	4.45	13.8	19.6	4.72	13.6	18.7	5.20	13.4	18.1	5.52	13.2
	30 / 22	21.6	3.92	14.9	21.0	4.28	14.6	20.7	4.45	14.5	20.2	4.72	14.3	19.1	5.23	14.1	18.3	5.58	13.9
200	22 / 16	20.1	4.32	15.2	19.5	4.77	14.8	19.2	4.97	14.7	18.7	5.27	14.5	17.8	5.81	14.1	17.1	6.16	13.9
	24 / 17	20.6	4.35	16.3	20.0	4.82	16.0	19.7	5.01	15.9	19.2	5.31	15.7	18.4	5.84	15.4	17.8	6.17	15.2
	26 / 19	21.8	4.43	16.2	21.2	4.90	15.9	20.9	5.09	15.8	20.4	5.39	15.6	19.6	5.91	15.3	19.1	6.23	15.1
	27 / 19.5	22.2	4.45	16.8	21.5	4.92	16.5	21.2	5.11	16.4	20.7	5.41	16.2	19.9	5.93	15.9	19.4	6.25	15.7
	28 / 21	23.3	4.51	16.1	22.6	4.97	15.8	22.2	5.17	15.7	21.7	5.47	15.5	20.8	6.00	15.2	20.2	6.34	15.0
	30 / 22	24.1	4.55	17.5	23.3	5.00	17.1	23.0	5.20	17.0	22.4	5.51	16.8	21.3	6.06	16.4	20.6	6.42	16.2

250	22 / 16	25.4	6.17	17.8	24.4	6.89	17.3	23.9	7.19	17.1	23.2	7.66	16.7	22.0	8.49	16.2	21.2	9.02	15.9
	24 / 17	26.4	6.23	19.0	25.2	6.93	18.5	24.7	7.23	18.2	24.0	7.70	17.9	22.8	8.52	17.4	22.0	9.04	17.1
	26 / 19	28.2	6.30	19.0	26.9	7.01	18.5	26.4	7.31	18.3	25.6	7.77	18.0	24.3	8.60	17.5	23.5	9.12	17.1
	27 / 19.5	28.6	6.32	19.6	27.3	7.02	19.1	26.8	7.32	18.9	26.0	7.79	18.5	24.7	8.62	18.0	23.9	9.14	17.7
	28 / 21	29.8	6.35	18.6	28.7	7.06	18.1	28.2	7.36	17.9	27.4	7.84	17.6	25.9	8.69	17.0	25.0	9.24	16.7
	30 / 22	30.6	6.36	19.1	29.6	7.08	18.6	29.1	7.39	18.4	28.3	7.88	18.0	26.8	8.75	17.5	25.7	9.31	17.2
300	22 / 16	29.3	7.1	20.7	28.1	8	20.1	27.6	8.3	19.8	26.8	8.9	19.5	25.4	9.8	18.8	24.5	10.4	18.5
	24 / 17	30.4	7.2	21.8	29	8	21.2	28.5	8.3	20.9	27.6	8.9	20.6	26.2	9.9	19.9	25.3	10.5	19.6
	26 / 19	32.5	7.3	21.4	31	8.1	20.8	30.4	8.5	20.6	29.5	9	20.2	28	10	19.6	27.1	10.7	19.3
	27 / 19.5	33	7.3	22	31.5	8.1	21.4	30.9	8.5	21.2	30	9	20.8	28.5	10.1	20.2	27.6	10.7	19.8
	28 / 21	34.3	7.4	21.5	33	8.2	21	32.4	8.6	20.7	31.5	9.2	20.4	30	10.1	19.8	29	10.8	19.5
	30 / 22	35.1	7.4	23.4	34	8.3	22.9	33.5	8.7	22.6	32.6	9.3	22.3	31	10.2	21.8	30	10.8	21.4

Ta = internal exchanger inlet air temperature

kWs = sensible cooling capacity (kW)

DB = dry bulb

kWf = Cooling capacity in kW

kWe = Compressor power input in kW

WB = wet bulb

The cooling capacities have not accounted for the heat dissipation of the centrifugal fan motors.

## PERFORMANCES OF SUPPLY AIR FANS

AIR FLOW: STANDARD

STATIC PRESSURE (Pa)			10	30	60	90	120	150	180	210
90	Standard air flow	l/s	750	705	647	570	458	278	-	-
	Sound pressure level	dB	70	69	69	68	63	60	-	-
100	Standard air flow	l/s	750	705	647	570	458	278	-	-
	Sound pressure level	dB	70	69	69	68	63	60	-	--
130	Standard air flow	l/s	-	861	830	783	714	611	333	-
	Sound pressure level	dB	-	68	67	66	66	65	64	-
150	Standard air flow	l/s	-	985	930	833	775	661	493	-
	Sound pressure level	dB	-	69	68	68	67	66	64	-
180	Standard air flow	l/s	-	1389	1330	1280	1222	1160	1083	1000
	Sound pressure level	dB	-	77	77	77	76	76	76	76
200	Standard air flow	l/s	-	1389	1330	1280	1222	1160	1083	1000
	Sound pressure level	dB	-	77	77	77	76	76	76	76
250	Standard air flow	l/s	-	-	1550	1500	1435	1370	1280	1200
	Sound pressure level	dB	-	-	80	80	78	78	78	78
300	Standard air flow	l/s	-	-	1830	1770	1690	1610	1500	1410
	Sound pressure level	dB	-	-	82	82	80	80	80	80

**DIMENSIONAL DRAWING**

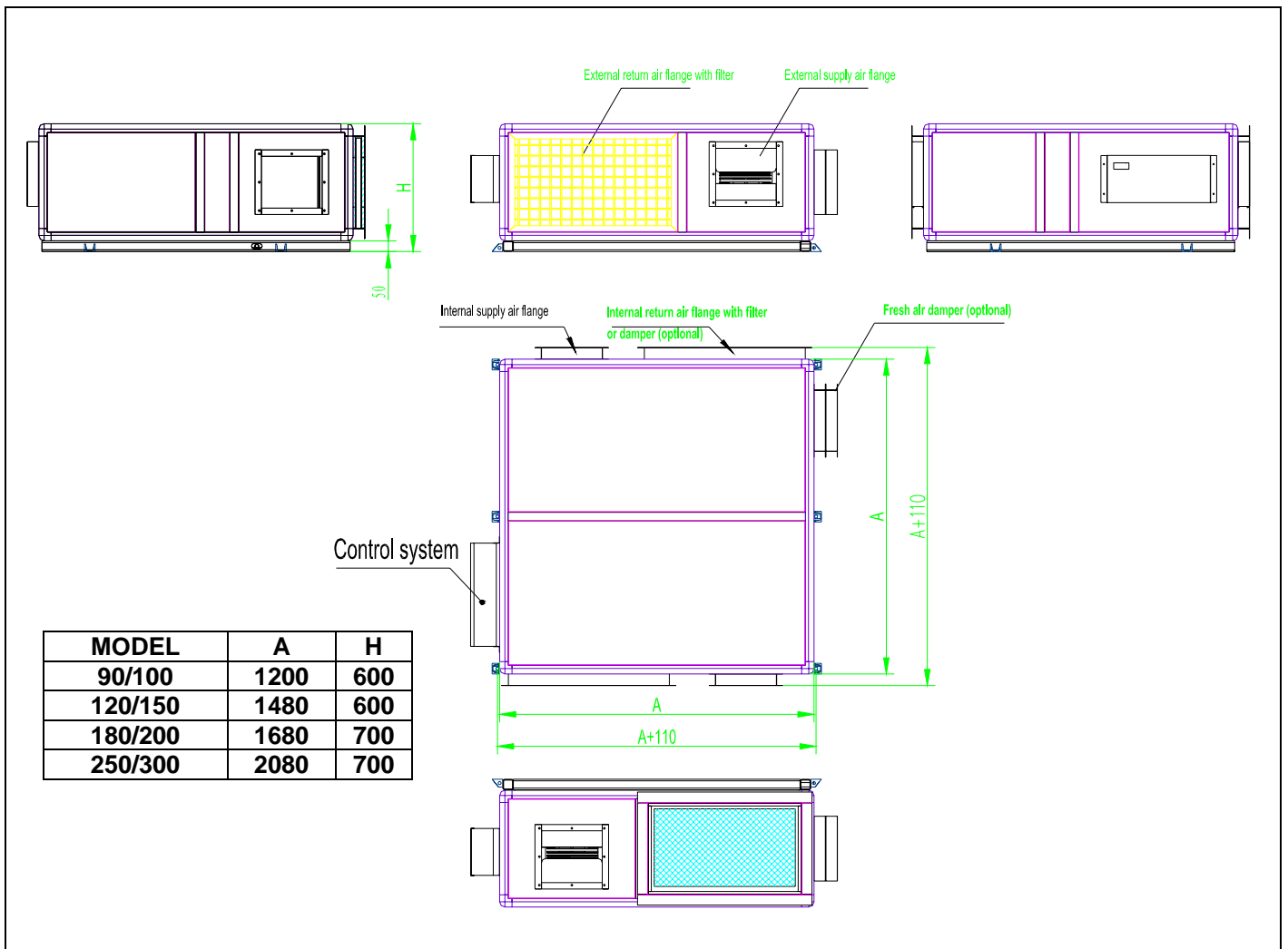

**WIRING DIAGRAMS**



**HPACK-ROOM-H WITH FREE COOLING**

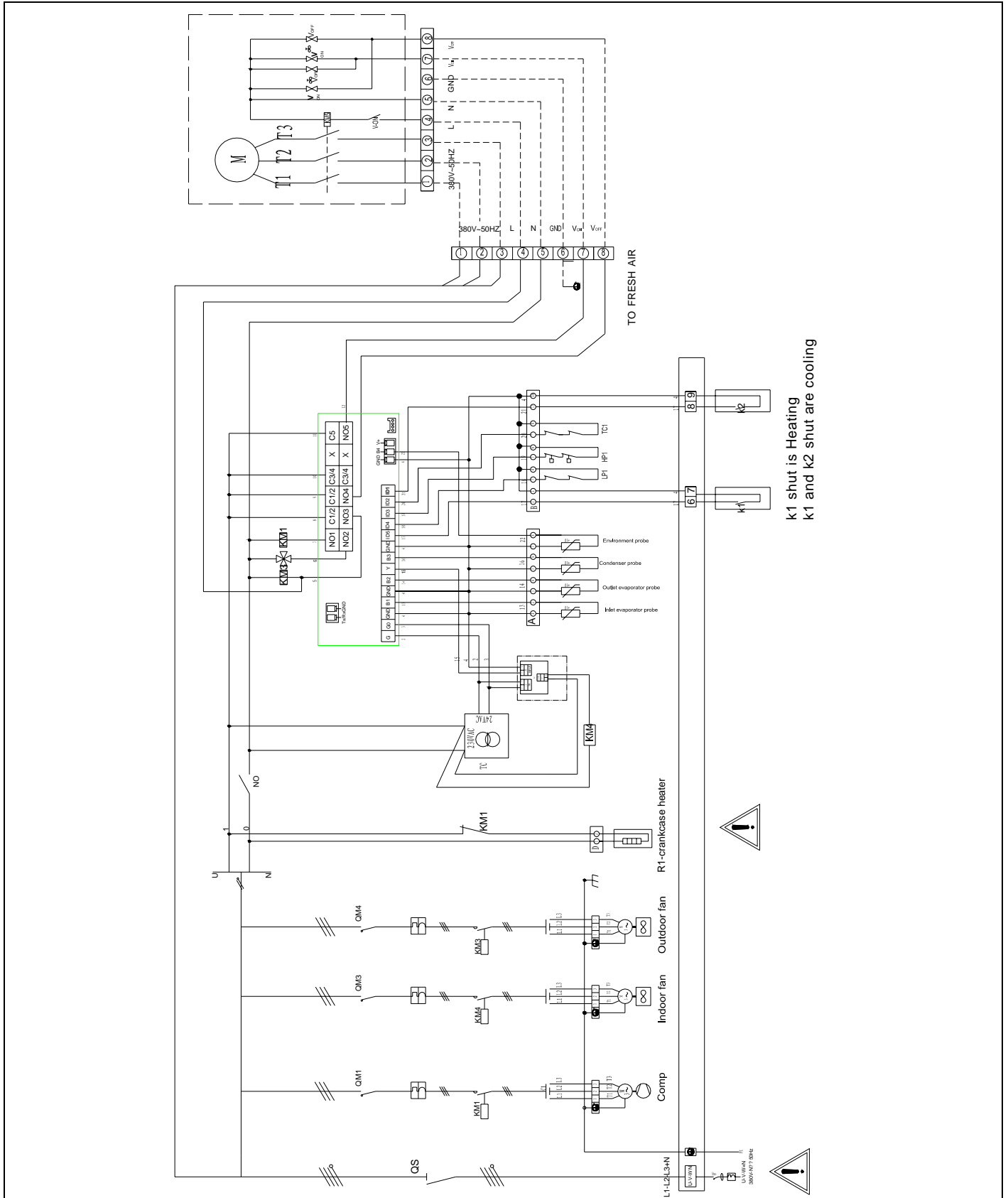

k1 shut is Heating  
k1 and k2 shut are cooling

**HPACK-ROOM-H WITH CO2 DETECTION**

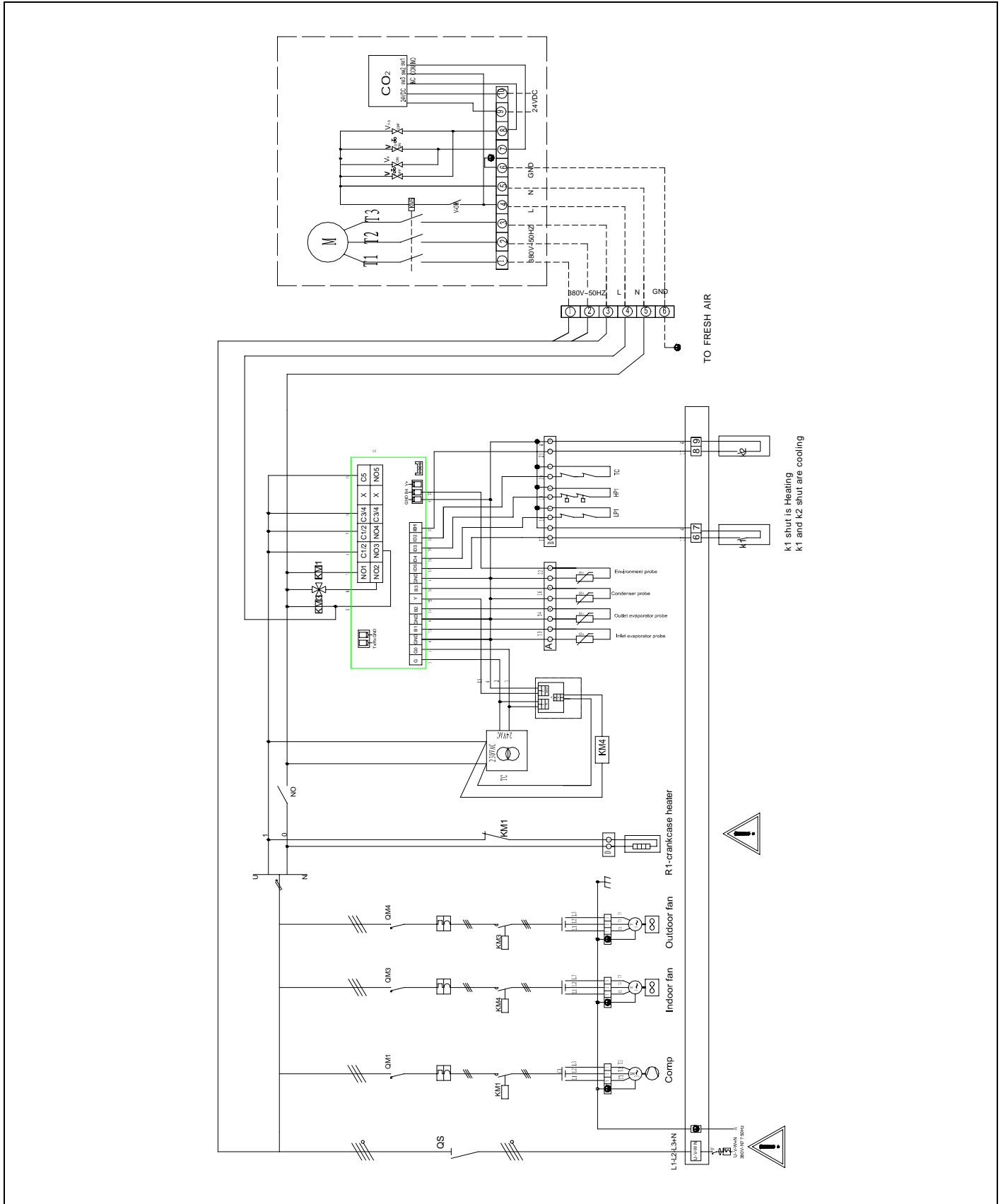

**I/O layout**

<b>μC2SE</b>	<b>Description</b>	<b>Expansion</b>	<b>Description</b>
B1	Control probe (returned air temperature)	B5	
B2	Protection probe (supply air temperature)	B6	
B3	Condenser temperature probe (1 <sup>st</sup> circuit)	B7	2 <sup>nd</sup> Cond. temperature probe
B4 (universal)	Environmental temperature probe	B8 (universal)	
ID1	P08=9 Cooling and heating mode selection (heat pump)	ID6	
ID2	P09=4 Power sequence protector and general thermal overload with automatic reset (N.C.)	ID7	P11=8 Thermal overload of compressor2
ID3	High pressure circuit 1	ID8	High pressure circuit 2
ID4	Low pressure circuit 1	ID9	Low pressure circuit 2
ID5	P34=23 Remote ON/OFF	ID10	
Y1	Ramp circuit1	Y2	Ramp circuit2
C1/2-NO1	Compressor 1	C6/7-NO6	Compressor2
C1/2-NO2	Reversing valve in 1st circuit	C6/7-NO7	Reversing valve in 2nd circuit
C /4-NO3	Supply Fan	C8/9-NO8	Backup pump
C /4-NO4	Auxiliary heater (optional)	C8/9-NO9	
C5-NO5	ALARM	C10-NO10	

**● SETTING AND OPERATING PARAMETERS**

**● User interface**

**1.1 Display**

The display features digits, with the display of the decimal point between -99.9 and 99.9. Outside of this range of measurement, the value is automatically displayed without the decimal (even if internally the unit still operates considering the decimal part).

In normal operation, the value displayed here is corresponding to a temperature being detected by probe B1 being of a temperature of water inlet.

Table 1.a below shows those symbols indicated on a display and on a key pad as well as respective meaning.

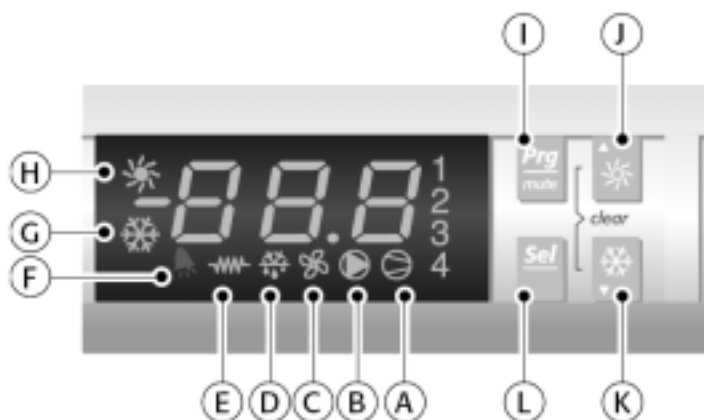

**1.2.2 Symbols on the display**

Display with green digits (plus sign and decimal point), amber symbols and red alarm symbols.











symbol	colour	meaning		reference refrigerant circuit
		with LED ON	con LED lampeggiante	
I; 2	amber	compressor 1 and/or 2 ON	start up request	1
I; 3	amber	compressor 3 and/or 3 ON	start up request	2
A	amber	at least one compressor ON		1/2
B	amber	pump/air outlet fan ON	start up request	1/2
C	amber	condenser fan ON		1/2
D	amber	defrost active	defrost request	1/2
E	amber	heater ON		1/2
F	red	alarm active		1/2
G	amber	heat pump mode (P6=0)	heat pump mode request (P6=0)	1/2
H	amber	chiller mode (P6=0)	chiller mode request (P6=0)	1/2

Table 1.a

### 1.2.3 Functions of buttons

Item	Functions	Operations
I	Loading default values	press at power ON
	Go up a sub-group inside the programming area, until exiting (saving changes to EEPROM)	press once
	In the event of alarms, mute the buzzer (if present) and deactivate the alarm relay	press once
L	Access the direct parameters	press for 5 s
	Select item inside the programming area and display value of direct parameters/confirm the changes to the parameters	press once
I+L	Program parameters after entering password	press for 5 s
J	Select top item inside the programming area	press once or press and hold
	Increase value	press once or press and hold
	Switch from standby to chiller mode (P6=) and vice versa	press for 5 s
K	Select bottom item inside the programming area	press once or press and hold
	Decrease value	press once or press and hold
	Switch from standby to heat pump mode (P6=0) and vice versa	press for 5 s
J+K	Manual alarm reset	press for 5 s
	Immediately reset the hour counter (inside the programming area)	press for 5 s
L+J	Force manual defrost on both circuits	press for 5 s

### 1.2.4 Programming and saving the parameters

- press “ **Prg** ” and “ **Sel** ” for 5 seconds;  

- the heating and cooling symbol and the figure “ 00 ” are displayed;
- use “  ” and “  ” to set the password and confirm by pressing “ **Sel** ” ;
- use “  ” and “  ” to select the parameter menu (S-P) or levels (L-P) and then press “ **Sel** ” ;
- use “  ” and “  ” to select the parameter group and then press “ **Sel** ” ;
- use “  ” and “  ” to select the parameter and then press “ **Sel** ” ;
- after making the changes to the parameter, press “ **Sel** ” to confirm or “ **Prg** ” to cancel the changes;  

8. press “ ” to return to the previous menu;

9. to save the modifications, press “ **Prg** mute ” repeatedly until reaching the main menu.

Note:

- a. the parameters that have been modified without being confirmed using the “ **Sel** ” button return to the previous value;
- b. if no operations are performed on the keypad for 60 seconds, the controller exits the parameter modification menu by timeout and the changes are cancelled.

### 1.2.5. Keypad

The keypad is used to set the unit operating values (see Parameters/alarms - Keypad combinations)

- **General parameters**

The parameters are divided into 4 different types, according to their level of access by the user (password) and their function.

For each level, only the access to the parameters of the same or lower level can be set.

This means that through “ factory ” password, accessing the menu “ levels ” (L-P), it is possible to set the desired level for each parameter.

- **factory parameters:** Accessible with the 66 “ Factory ” password, allow the configuration of all the unit parameters.
- **Super User parameters:** Accessible with the 11 “ Super User ” password, allow the configuration of the Super User, User and Direct parameters.
- **User parameters:** Accessible with password 22, allow the configuration of the parameters that typically can be set by the user (User parameters) and the Direct parameters, consequently relating to the options.
- **Direct parameters:** Accessible without password, this are used to read the probe measurements and any data, by any user, without compromising the operation of the unit.

**N.B.:** The modifications to the parameters regarding the configuration of the unit (type, number of compressors,...) must be performed with the controller in Standby.

level	level name	password
d	direct	no password
U	user	22
S	super user	11
F	factory	66



● Menu structure

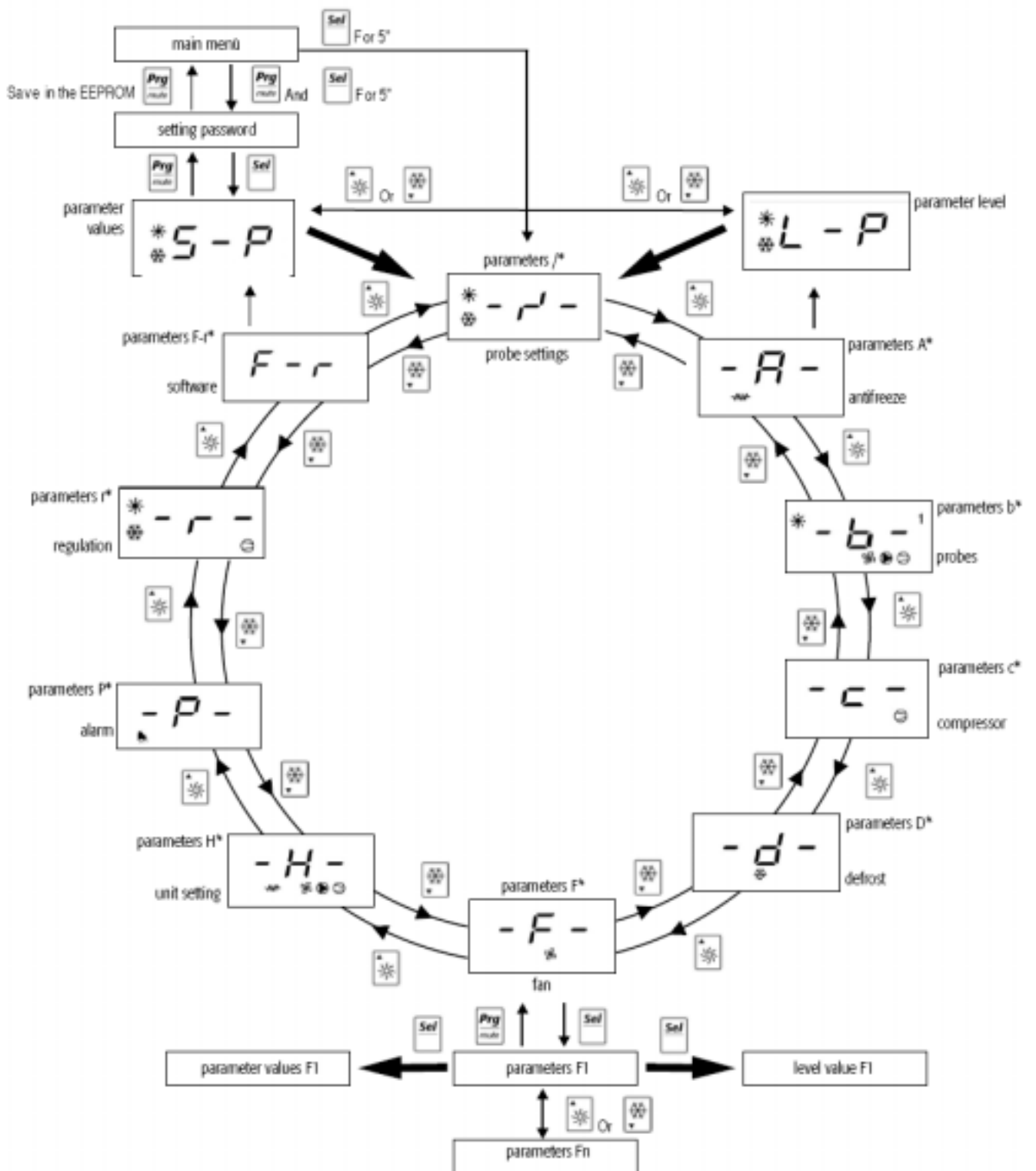

Fig. 4.a

● **Parameter table**

Following series of tables show various parameters by type/family

● **Key to the parameter tables**

Level (default)

S= super user F= factory D= direct

● **Visibility:**

Visibility depends on type of controller and value of parameter

D= defrost (if D01=1) F= fan (if F01=1)

N= NTC probe (if /04-/08=2) P= pressure (if /04-/08= ) V= driver (if H08 =1- )

X= expansion (if H08=2- ) - = always present

● **Supervisor variables:**

R/W = supervisor read/write parameter R= supervisor read-only parameter

**1.1 Probe setting parameters (\*):**

display indicat.	parameter and description	default level	min.	max.	U.O.M.	variat.	default	visibility	supervis. variable	Modbus	variable type	
/01	Probe type B1	0=not present	F	0	1	Flag	1	1	-	1 (R/W)	1	Digital
		1= present										
/02	Probe type B2	0=not present	F	0	1	Flag	1	1	-	2 (R/W)	2	Digital
		1= present										
/03	Probe type B3	0=not present	F	0	2	flag	1	1	-	14 (R/W)	142	Integer
		1=NTC Cond. Probe										
		2= NTC Out. Probe										
/04	Probe type B4	0=not present	F	0	3	flag	1	2	-	15 (R/W)	143	Integer
		1=ON/OFF (D.I)										
		2= NTC Out. Probe										
		3=radiometric cond. Probe, 5 Vdc										
/05	Probe type B5	0=not present	F	0	1	Flag	1	0	X	(R/W)	-	Digital
		1= present										
/06	Probe type B6	0=not present	F	0	1	Flag	1	0	X	4 (R/W)	4	Digital
		1= present										
/07	Probe type B7	0=not present	F	0	2	flag	1	1	X	16 (R/W)	144	Integer
		1=NTC Cond. Probe										
		2= NTC Out. Probe										
/08	Probe type B8 (expansion)	0=not present	F	0	4	int	1	0	X	17 (R/W)	145	Integer
		1= ON/OFF										
		2= NTC Out. Probe										
		3=radiometric cond. Probe, 5 Vdc										

**1.2 Antifreeze/auxiliary heater setting parameters (A\*)**

display indicat.	parameter and description	default level	min.	max.	U.O.M.	variatio.	default	visibility	supervis. variable	Modbus	variable type
A01	Antifreeze alarm set point	U	A07	A04	° C	0.1	30	-	11 (R/W)	11	Analog
A02	Differential for antifreeze alarm	U	0.3	122.0	° C	0.1	50	-	12 (R/W)	12	Analog
A03	Bypass time for antifreeze alarm when turning on the unit in heating mode	U	0	150	S	1	0	-	22 (R/W)	150	Integer
A04	Set point for the activation of antifreeze auxiliary heater	U	A01	r16	° C	0.1	50	-	1 (R/W)	13	Analog
A05	Diff. for antifreeze auxiliary heater	U	0.3	50.0	° C	0.1	50	-	14 (R/W)	14	Analog
A06	Auxiliary heater probe 0= Control probe see (B1) 1= Antifreeze probe see (B2)	F	0	1	Flag	1	0	-	6 (R/W)	6	Digital
A07	Antifreeze alarm set point limit	F	-40.0	176.0	° C	0.1	0	-	15 (R/W)	15	Analog
A08	Auxiliary heater set point in heating mode	U	A01	r16	° C	0.1	25.0	-	16 (R/W)	16	Analog
A09	Auxiliary heater differential in heating mode	U	0.3	50.0	° C	0.1	.0	-	17 (R/W)	17	Analog
A10	Antifreeze automatic start up 0= disabled function 1= Heaters and pump on at the same time on A4/A8 2= Heaters and pump on independently on A4/A8 3= Heaters ON on A4/A8	U	0	3	Flag	1	0	-	2 (R/W)	151	Integer

**1.3 Probe reading parameters (b\*)**

display indicat.	parameter and description	default level	min.	max.	U.O.M.	variat.	default	visibility	supervis. variable	Modbus	variable type
b00	Config. of probe to be shown on the display	U	0	10	Flag	1	0	-	24 (R/W)	152	integer
	0= probe B1										
	1= probe B2										
	2= probe B3										
	3= probe B4										
	4= probe B5										
	5= probe B6										
	6= probe B7										
	7= probe B8										
	8= set point without compensation										
9= dynamic set point with possible compensation											
10= remote ON/OFF digital input status											
b01	Value read by probe B1	D	-	-	° C	-	-	-	70 (R)	70	Analog
b02	Value read by probe B2	D	-	-	° C / ° F	-	-	-	71 (R)	71	Analog
b03	Value read by probe B_	D	-	-	° C / ° F	-	-	-	72 (R)	72	Analog
b04	Value read by probe B4	D	-	-	° C	-	-	-	7 (R)	73	Analog
b05	Value read by probe B5	D	-	-	° C	-	-	X	74 (R)	74	Analog
b06	Value read by probe B6	D	-	-	° C	-	-	X	75 (R)	75	Analog
b07	Value read by probe B7	D	-	-	° C	-	-	X	76 (R)	76	Analog
b08	Value read by probe B8	D	-	-	° C	-	-	X	77 (R)	77	Analog

**1.4 Compressor setting parameters (c\*)**

display indicat.	parameter and description	default level	min.	max.	U.O.M.	variat.	def.	visibi- lity	supervis. variable	Modbus	variable type
c01	Min. compressor ON time	U	0	999	s	1	360	-	25 (R/W)	15_	Integer
c02	Min. OFF time compressor	U	0	999	s	1	360	-	26 (R/W)	154	Integer
c03	Delay between 2 starts of the same compressor	U	0	999	s	1	360	-	27 (R/W)	155	Integer
c04	Delay between starts of the 2 compressors	U	0	999	s	1	30	-	28 (R/W)	156	Integer
c05	Delay between 2 shut-downs of the 2 compressors	U	0	999	s	1	10	-	29 (R/W)	157	Integer
c06	Delay at start-up	U	0	999	s	1	0	-	0 (R/W)	158	Integer
c07	Delay in switching on the compressor after switching on the pump	U	0	150	s	1	30	-	1 (R/W)	159	Integer
c08	Delay in switching OFF the compressor after switching OFF the pump	U	0	150	min	1	1	-	2 (R/W)	160	Integer
c09	Maximum compressor operating time in tandem	U	0	60	min	1	0	-	(R/W)	161	Integer
c10	Compressor 1 timer	D	0	800.0	100 hours	0.1	0	-	90 (R)	90	Analog
c11	Compressor 2 timer	D	0	800.0	100 hours	0.1	0	-	91 (R)	91	Analog
c12	Compressor timer	D	0	800.0	100 hours	0.1	0	-	92 (R)	92	Analog
C13	Compressor 4 timer	D	0	800.0	100 hours	0.1	0	-	9 (R)	9_	Analog
c14	Operation timer threshold	U	0	100	100 hours	1	0	-	4 (R/W)	162	Integer
c15	Hour counter evaporator pump/fan 1	D	0	800.0	100 hours	0.1	0	-	94 (R)	94	Analog
c16	Hour counter condenser backup pump	D	0	800.0	100 hours	0.1	0	-	95 (R)	95	Analog
c17	Minimum time between 2 pump starts	U	1	150	min	1	0	-	5 (R/W)	16_	Integer
c18	N time	U	1	15	min	1	_	-	_	164	

**1.5 Defrost setting parameters (d\*)**

display indicat.	parameter and description	default level	min.	max.	U.O.M.	variatio.	def.	visibility	supervis. variable	Modbus	variable type
d01	Defrosting cycle 0= defrost disabled 1= defrost enabled	U	0	1	Flag	1	1	-	7 (R/W)	7	Digital
d02	Defrosting based on time or temp. 0= time 1= temp.(B4/B8) 2= pressure start, temperature end	U	0	2	Flag	1	1	D	90 (R/W)	218	Integer
d03	Start defrosting temperature set point	U	-40.0	d04	° C	0.1	-5.0	DN	19 (R/W)	19	Analog
	Start defrosting pressure		/11	d04	bar	0.1	3.5	DP	18 (R/W)	18	Analog
d04	End defrosting temperature	U	d03	176	° C	0.1	20.0	DN	21 (R/W)	21	Analog
	End defrosting pressure		d03	/12	bar	0.1	14.0	DP	20 (R/W)	20	Analog
d05	Min. time to start a defrosting cycle	U	10	150	s	1	150	D	7 (R/W)	165	Integer
d06	Min. duration of a defrosting cycle	U	0	150	s	1	0	D	8 (R/W)	166	Integer
d07	Max. duration of a defrosting cycle	U	1	150	min	1	5	D	9 (R/W)	167	Integer
d08	Delay between 2 defrosting cycle requests within the same circuit	U	10	150	min	1	30	D	40 (R/W)	168	Integer
d09	Defrosting delay between the 2 circuits	U	0	150	min	1	10	D	41 (R/W)	169	Integer
d10	Defrost by external contact 0=disable function	F	0	-	Flag	1	0	D	42 (R/W)	170	Integer
	1=external contact start										
	2=external contact end										
	3=external contact start and end										
d11	Antifreeze heaters activated while defrosting	U	0	1	Flag	1	0	D	9 (R/W)	9	Digital
	0=Not present; 1=Present										
d12	Waiting time before defrosting	F	0	-	min	1	0	D	4 (R/W)	171	Integer
d13	Waiting time after defrosting	F	0	-	min	1	0	D	44 (R/W)	172	Integer
d14	End defrosting with 2 refrigerating circuits	F	0	2	Flag	1	0	D	45 (R/W)	173	Integer
	0= Independent										
	1= If both at end defrost 2= If at least one at end defrost										
d15	Start defrost with 2 circuits 0= Independent 1= If both at start defrost	F	0	2	Flag	1	0	D	46 (R/W)	174	Integer

	2= If at least one at start defrost										
d16	Forced ventilation time at the end of the defrosting	F	0	60	s	1	0	D	47 (R/W)	175	Integer
d17	Defrost with compressors OFF	F	0	80.0	° C	0.1	0	D	22 (R/W)	22	Analog

**1.6 fan setting parameters (f\*)**

display indicat.	parameter and description	default level	min.	max.	U.O.M.	variat.	def.	visibility	supervis. variable	Modbus	variable type
F01	Fan output	F	0	1	Flag	1	0	-	10 (R/W)	10	Digital
	0= absent										
	1= present										
F02	Fan operating mode	U	0	-	Flag	1	0	F	48 (R/W)	176	Integer
	0= always ON										
	1= depending ON the compressor(in parallel operation mode)										
	2= depending ON the compressors in ON/OFF control										
	3= depending ON the compressors in speed control mode										
F03	Min. voltage threshold for Triac	F	0	F04	step	1	5	F	49 (R/W)	177	Integer
F04	Max. voltage threshold for Triac	F	F03	100	step	1	75	F	50 (R/W)	178	Integer
F05	Temp. value for min. speed Cooling	U	-40.0		° C	0.1	35.0	FN	24 (R/W)	24	Analog
	Pressure value for min. speed Cooling										
F06	Differential value for max. speed Cooling	U	0	50.0	° C	0.1	10.0	FN	26 (R/W)	26	Analog
	Differential pressure value for max. speed Cooling										
F07	Fan shut-down differential in Cooling mode	U	0	50.0	° C	0.1	15.0	FN	28 (R/W)	28	Analog
	Fan shut-down differential pressure in Cooling mode										
F08	Temperature value for max speed in Heating mode	U	-40.0		° C	0.1	5.0	FN	30 (R/W)	30	Analog
	Pressure value for max speed in Heating										
F09	Differential temperature value for max. speed in Heating mode	U	0	50.0	° C	0.1	5.0	FN	32 (R/W)	32	Analog
	Differential pressure value for max speed in Heating										
F10	Differential temperature to turn OFF the fan in Heating	U	0	F08	° C	0.1	5.0	FN	34 (R/W)	34	Analog
	Differential pressure to turn OFF the fan in										

ROOM-TOP AIR-CONDITIONER 90-200 ..... 25

Heating											
F11	Fan starting time	U	0	120	s	1	0	F	51 (R/W)	179	Integer
F12	Triac impulse duration (fan start)	F	0	10	s	1	2	F	52 (R/W)	180	Integer
F13	Fan management in defrost mode 0= Disabled fans	F	0	2	Flag	1	0	F	53(R/W)	181	Integer
	1= Fan in chiller mode										
	2= Max. speed after defrost										
F14	Fan on time when starting in high condensing temperature	U	0	999	S	1	0	FN	91(R/W)	219	Integer

1.7 Unit setting parameters (h\*)

display indicat.	parameter and description	default level	min.	max.	U.O.M.	vari.	def.	visibility	supervis. variable	Modbus	variable type
H01	Unit model	F	0	10	Flag	1	1 (heat pump)  0 (cooling only)	-	54 (R/W)	182	Integer
	0= air-air unit										
	1= air-air heat pump										
	2= air-water chiller										
	3= air-water heat pump										
	4= water-water chiller										
	5= water-water heat pump with reversal on gas circuit										
	6= water-water heat pump with reversal on water circuit										
	7= condensing unit										
	8= reverse-cycle condensing unit										
	9= water-cooled condensing unit										
10= reverse-cycle water-cooled condensing unit											
H02	Number of condensers 0=1 circuit; 1=2 circuits	F	0	1	Flag	1	1	F	12 (R/W)	12	Digital
H03	Number of evaporators	F	0	1	Flag	1	0	-	13 (R/W)	13	Digital
	0=1 evaporator										
	1=2 evaporators										
H04	Number of compressors per circuit	F	0	5	Flag	1	0 (200/ 250/ 300/ 350/ 400 450)  2 (500/ 600/ 700/ 1000)	-	55 (R/W)	183	Integer
	0=1 comp. ON 1 circuit (single circuit)										
	1=2 comp. in tandem ON 1 circuit (single circuit)										
	2=1 comp. per circuit, 2 circuits (two circuits)										
	3=2 comp. in Tandem, 2 circuits (two circuits)										
	4=1 compressor and 1 Capacity step in one circuit										

ROOM-TOP AIR-CONDITIONER 90-200 .....26

	5=1 compressor and 1 capacity Step per circuit outlet fan (Air/Air) mode (output N2) 0= absent 1= always ON 2= ON upon request of the controller 3= ON upon request of the controller and for set time 4= follow hot keep or hot start in heating, always on in cooling 5= follow hot keep or hot start in heating, follow the comp. in cooling	F	0	5	Flag	1	4	-	56 (R/W)	184	Integer
H06	Cooling/Heating digital input 0= absent 1= present	U	0	1	Flag	1	1(heat pump) 0(chiller)	-	14 (R/W)	14	Digital
H07	ON/OFF digital input 0= absent 1= present	U	0	1	Flag	1	1	-	15 (R/W)	15	Digital
H08	µC2network configuration 0= µC2only 1= µC2+ valve 2= µC2+ exp. 3= µC2+exp.+valve	F	0	-	Flag	1	2 (over 500) 0 (less 500)	-	57 (R/W)	185	Integer
H09	Lock keypad 0= disabled 1= enabled	U	0	1	Flag	1	1	-	16 (R/W)	16	Digital
H10	Serial address	U	1	200	-	1	1	-	58 (R/W)	186	Integer
H11	Output modes	F	0	12	Flag	1	0	-	59 (R/W)	187	Integer
H12	Capacity- control logic valve and inversion valve 0= Both normally closed 1= Both normally open 2= Inversion valve normally open and capacity-control valve normally closed 3= Inversion valve normally closed and capacity-control valve normally open	F	0	-	Flag	1	1	-	60 (R/W)	188	Integer
H21	Second pump function 0= Disabled 1= Backup and weekly rotation 2= Backup and daily rotation 3= Condensing control on corresponding set	F	0	4	int	1	0	-	62 (R/W)	269	Integer

	point 4= Condensing control always on											
H22	Disable load default values 0= Function disabled 1= Function enabled	F	0	1	Flag	1	0	-	18 (R)	18	Digital	
H23	Enable Modbus protocol	F	0	1		1	0	-	11	11	Digital	

### 1.8 Alarm setting parameters (P\*)

display indicat.	parameter and description	default level	min.	max.	U.O.M.	variat.	def.	visibility	supervis. variable	Modbus	variable type
P01	Flow switch alarm delay when starting the pump	U	0	150	S	1	30	-	63(R/W)	191	Integer
P02	Flow switch alarm delay during steady operation	U	0	120	S	1	5	-	64(R/W)	192	Integer
P03	Low pressure alarm delay at start-up	U	0	200	S	1	60	-	65(R/W)	193	Integer
P04	Enable part load in high pressure	U	0	3	int	1	0	P	66(R/W)	194	Integer
P05	Alarm reset 0=HP1-2/LP1-2/A1-2/Lt manual 1= HP1-2/LP1-2/A1-2/Lt automatic 2= HP1-2/A1-2/Lt manual LP1-2 automatic 3= HP1-2 manual LP1-2/A1-2/Lt automatic 4= HP1-2/LP1-2 manual A1-2/Lt automatic 5= HP1-2/LP1-2 (thrice per hour) manual A1-2/Lt automatic 6= HP1-2/LP1-2 (thrice per hour) manual; A1-2/Lt manual	F	0	6	int	1	0	-	67(R/W)	195	Integer
P06	Cooling/heating logic 0= ❄️ Chiller, ❄️ Heat pump 1= ❄️ Heat pump, ❄️ Chiller	F	0	1	Flag	1	0	-	19(R/W)	19	Digital
P07	Low pressure alarm from transducer 0= Disabled 1= Enabled	F	0	1	Flag	1	0	P	68(R/W)	196	Integer
P08	Digital input 1 selection 0= N 1=FL man. 2=FL auto. 3=TP man. 4=TP auto 5= TC1 man. 6= TC1 auto. 7= TC2 man. 8= TC2 auto. 9= Cool/Heat. 10= Cool/Heat. Delayed 11= LA man. 12= LA auto. 13= 2 ° Set 14= 2 ° Set timer 15= stop defrost c. 1 16= stop defrost c. 2 17= start defrost c. 1 18= start defrost c. 2 19= step 1 20 = step 2 21= step 22= step 4	F	0	22	Flag	1	10	-	69(R/W)	197	Integer



ROOM-TOP AIR-CONDITIONER 90-200 ..... 29

	4= time on outlet with dead zone										
r07	Dead zone differential	F	0.1	50.0	° C/ ° F	0.1	2.0	-	45 (R/W)	45	Analog
r08	Activation delay at lower limit of r07	F	0	999	s	1	120	-	80 (R/W)	208	Integer
r09	Activation delay at upper limit of r07	F	0	999	s	1	100	-	81 (R/W)	209	Integer
r10	Deactivation delay at lower limit of r12	F	0	999	s	1	120	-	82 (R/W)	210	Integer
r11	Deactivation delay at upper limit of r12	F	0	999	s	1	100	-	8 (R/W)	211	Integer
r12	Compressor deactivation differential	F	0	50.0	° C/ ° F	0.1	2.0	-	46 (R/W)	46	Analog
r13	Min. Cooling set point	U	-40.0	r14	° C/ ° F	0.1	2.0	-	47 (R/W)	47	Analog
r14	Max. Cooling set point	U	r1_		° C	0.1	20	-	48 (R/W)	48	Analog
r15	Min. Heating set point	U	-40.0	r16	° C/ ° F	0.1	10	-	49 (R/W)	49	Analog
r16	Max. Heating set point	U	r15	176.0	° C	0.1	50	-	5	50	Analog
r17	Cooling compensation constant	U	-5.0	+5.0	-	0.1	0.0	-	51 (R/W)	51	Analog
r18	Maximum distance from the set point	U	0.3	20.0	° C/ ° F	0.1	1	-	52 (R/W)	52	Analog
r19	Start compensation temperature in cooling mode	U	-40	176.0	° C/ ° F	0.1	0.0	-	5 (R/W)	5_	Analog
r20	Start compensation temperature in heating mode	U	-40	176.0	° C/ ° F	0.1	0	-	54 (R/W)	54	Analog
r21	Second cooling set point from external contact	D	r13	r14	° C/ ° F	0.1	12.0	-	55 (R/W)	55	Analog
r22	Second heating set point from external contact	D	r15	r16	° C/ ° F	0.1	40.0	-	56 (R/W)	56	Analog
r27	Enable accumulation vessel suppression	F	0	_	flag	1	0	-	88 (R/W)	216	Integer
	0= Disabled										
	1= Enabled in cool										
	2= Enabled in Heat = Always enabled										
r28	Minimum time to determine low load conditions	F	0	999	s	1	60	-	89 (R/W)	217	Integer
r29	Low load differential in chiller mode	F	0.3	50.0	° C/ ° F	0.1	3.0	-	58 (R/W)	58	Analog
r30	Low load differential in heat pump mode	F	0.3	50.0	° C/ ° F	0.1	3.0	-	59 (R/W)	59	Analog
r 31	Heating compensation constant	U	-5.0	+5.0	-	0.1	0.0	-	6	60	

## ● TABLE OF ALARMS

Key to the table of alarms:

\*: if the probe is set for the compensation function, in the event of probe faults, the unit continues to operate.

alarm display	Alarm type	resetting	Compressor	pump	fan	heater	Valve	alarm	warning	superv. variable	superv. variab. description	variab. type
HP1	High pressure	Depends on P05	OFF C1-2	-	ON(60")	-	-	ON	-	1 (R)	Circuit 1 alarm	Digital
HP2	High pressure	Depends on P05	OFF C3-4	-	ON(60")	-	-	ON	-	2 (R)	Circuit 2 alarm	Digital
LP1	Low pressure	Depends on P05	OFF C1-2	-	OFF 1	-	-	ON	-	1 (R)	Circuit 1 alarm	Digital
LP2	Low pressure	Depends on P05	OFF C3-4	-	OFF 2	-	-	ON	-	2 (R)	Circuit 2 alarm	Digital
TP	General overload	Depends on P08	OFF	OFF	OFF	-	-	ON	-	5 (R)	General warning	Digital
tC1	Circuit 1 overload	Depends on P08	OFF C1-2	-	OFF 1	-	-	ON	-	1 (R)	Circuit 1 alarm	Digital
tC2	Circuit 2 overload	Depends on P08	OFF C -4	-	OFF 2	-	-	ON	-	2 (R)	Circuit 2 alarm	Digital
LA	advice	Depends on P08	-	-	-	-	-	ON*	ON	40 (R)	General advice	Digital
FL	Flow controller alarm	Depends on P08	OFF	OFF	OFF	-	-	ON	-	5 (R)	General alarm	Digital
FLb	Backup pump warning	Automatic	-	-	-	-	-	-	ON	40 (R)	General advice	Digital
E1	Probe B1 alarm	Automatic	OFF	OFF	OFF	OFF	-	ON	-	6 (R)	Probe alarm	Digital
E2	Probe B2 alarm	Automatic	OFF	OFF	OFF	OFF	-	ON	-	6 (R)	Probe alarm	Digital
E3 *	Probe B3 alarm	Automatic	OFF	OFF	OFF	OFF	-	ON	-	6 (R)	Probe alarm	Digital
E4*	Probe B4 alarm	Automatic	OFF	OFF	OFF	OFF	-	ON	-	6 (R)	Probe alarm	Digital
E5	Probe B5 alarm	Automatic	OFF	OFF	OFF	OFF	-	ON	-	6 (R)	Probe alarm	Digital
E6	Probe B6 alarm	Automatic	OFF	OFF	OFF	OFF	-	ON	-	6 (R)	Probe alarm	Digital
E7*	Probe B7 alarm	Automatic	OFF	OFF	OFF	OFF	-	ON	-	6 (R)	Probe alarm	Digital
E8*	Probe B8 alarm	Automatic	OFF	OFF	OFF	OFF	-	ON	-	6 (R)	Probe alarm	Digital
Hc1-4	Hour warning C1-4	Automatic	-	-	-	-	-	-	ON	7 (R)	Compressor advice	Digital
EPr	EEPROM error during operation	Automatic	-	-	-	-	-	-	ON	40 (R)	General advice	Digital
EPb	EEPROM error at the start-up	Automatic	OFF	OFF	OFF	OFF	OFF	OFF	OFF	5 (R)	General alarm	Digital
ESP	Expansion Error	Automatic	OFF	OFF	OFF	OFF	OFF	ON	-	5 (R)	General alarm	Digital
EL1-2	Zero cross	Automatic	-	-	100%	-	-	ON*	ON	42 (R)	Fan advice	Digital

**ROOM-TOP AIR-CONDITIONER 90-200 .....31**

dF1-2	Defrosting error	Automatic	-	-	-	-	-	-	ON	40 (R)	General warning	Digital
d1-2	Defrost on circuit in question	-	-	-	-	-	-	-	-	-	Signal on display	-
A1	Frost alarm circ. 1	Depends on P05	OFF C1-2	-	OFF 1	-	-	ON	-	1 (R)	Circuit 1 alarm	Digital
A2	Frost alarm circ. 2	Depends on P05	OFF C -4	-	OFF 2	-	-	ON	-	2 (R)	Circuit 2 alarm	Digital
Ht	High temperature	Automatic	-	-	-	-	-	ON*	ON	41 (R)	Temperature advice	Digital
Lt	Low ambient temp.	Depends on P05	-	-	-	-	-	ON*	ON	41 (R)	Temperature advice	Digital
AHt	High temperature at the start-up	Automatic	OFF	-	OFF	OFF	-	-	ON	40 (R)	General warning	Digital
ALt	Low temperature at the start-up	Automatic	OFF	-	OFF	OFF	-	-	ON	40 (R)	General warning	Digital
ELS	Low supply voltage	Automatic	-	-	-	-	-	-	ON	40 (R)	General warning	Digital
EHS	High supply voltage	Automatic	OFF	OFF	OFF	OFF	OFF	OFF	OFF	5 (R)	General alarm	Digital

**Note**

- Warning Relay differs from Alarm Relay as it is activated only for warnings: signal only to have no direct effect on operation of unit. The display, thus, does not show Alarm symbol (bell).

- An alarm relating to faulty circuit is independent and not interact with an operation of other circuit, i.e. the Condenser is not shared in common.